

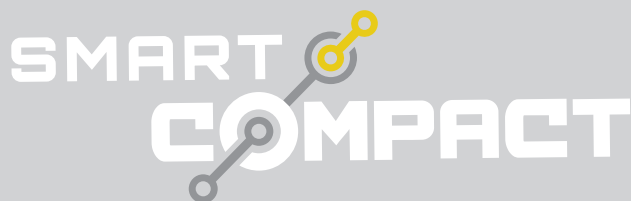





COMPACT POWER UNIT SMART-COMPACT XL



Part-no.
1103640



-  **COMPACT**
-  **ECO**
-  **CONNECT**
-  **18V BATTERY**
-  **POW3R PUMP**
-  **LED LIGHTS**

Technical Data:

Nominal pressure	700 bar
Oil volume	6.1 l
Useable volume	5.1 l
Dimensions	509 x 210 x 335 mm
Weight ready to use*	14.7 kg
Part-no.	1103640

* Supplied without battery, weight and dimensions and 6,0 Ah MILWAUKEE M18™ FORGE™ battery

** For longer runtimes, operation with 1x 12,0 Ah MILWAUKEE M18™ FORGE™ battery is recommended

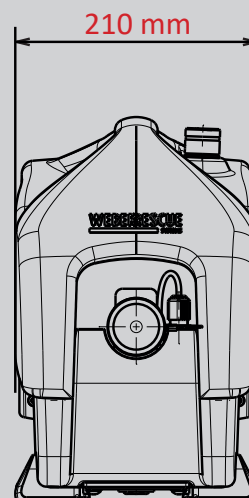
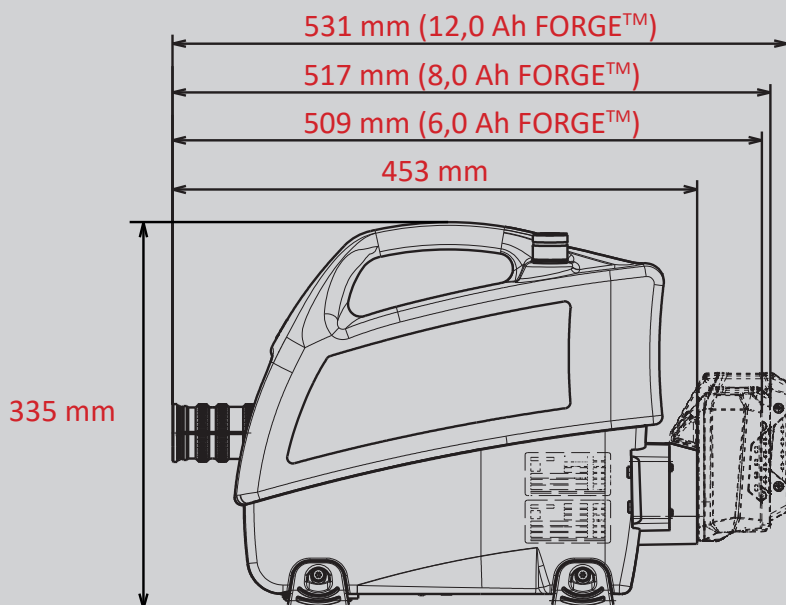

Illustrations are not binding. Subject to technical changes. Version, 11/2024A